

BIZERBA

_balanced information

III/133e



BIZERBA | FULLY AUTOMATIC SLICER

VS 12 D-V



→ PRECISION DELI SLICER WITH VERSATILE
LAYOUT PROGRAMS.



COMPACT AND FULLY AUTOMATED MEETING THE HIGHEST STANDARDS

The VS 12D-V is a universal precision slicer with many flexible applications. It features a motorised carriage and robust product holder, and provides a variety of layout options **entirely without manual handling**.

The cutting speed can be controlled with three carriage speeds and three stroke adjustments for the carriage movements. The fully automated controls provides you with the exact speed for comfortable and safe handling.

→ Optional

- Stainless steel stand with guide rollers and lock
- Teflon blade
- Round plate for star shaped layout pattern



TECHNICAL DATA



| Current | Voltage*) | Frequency | Operating current | Power consumption | | | | |
|---------------------------------------|-------------------------------|-----------|----------------------------|-------------------|----------------------------------|--|-----------------|----------------|
| | V | Hz | A | kW | → Outside dimension mm (inches): | L 620 (24.4") | W 970 (38.2") | H 495 (19.5") |
| → 1-phase AC: | 120 230 | 60 50 | 4.2 2.0 | 0.504 0.460 | → Footprint mm (inches): | L1 515 (20.3") | W1 430 (16.9") | |
| → 3-phase AC: | 230/400 | 50 | 1.9/1.38 | 0.552 | → Operating area mm (inches): | L2 825 (32.5") | W2 1040 (40.9") | H2 690 (27.2") |
| → Blade diameter: | 330 mm (13") | | | | → Stack height: | 60 mm (2.4") | | |
| → Blade speed: | 266 r.p.m. | | | | → Protection class: | IP 33 | | |
| → Carriage strokes: | long | medium | short | | → Box dimensions: | 58 x 82 x 70 cm (L x W x H) (22.8" x 32.2" x 27.6") (L x W x H) | | |
| | 30-40-50 | 35-48-58 | 60-68-75 | | → Weight: | approx. 75kg (net) / 87kg (gross) | | |
| → Product size | min. | | max. | | → Carriage table: | 254 x 346 mm (10" x 13.6") | | |
| - with depositing arm: | 50 x 50 mm (1.97" x 1.97") | | 183 x 240 mm (7.2" x 9.4") | | → Paper size: | 1/8 sheet - 250 x 375 mm (9.8" x 14.8") | | |
| - without depositing arm: | 224 x 260 mm (8.82" x 10.24") | | | | → Deposit table: | 240 x 360 mm (9.7" x 14.2") | | |
| → Infinitely variable slice thickness | | | | | → Table slide distance: | 160 mm (6.3") | | |
| - with depositing arm: | 0.5 to 8 mm (0.02" to 0.3") | | | | → Optional: | Round plate for star shaped product layout, product clamping device, teflon blade, | | |
| - without depositing arm: | 0.5 to 24 mm (0.02" to 0.94") | | | | | | | |

→ Dimensions:

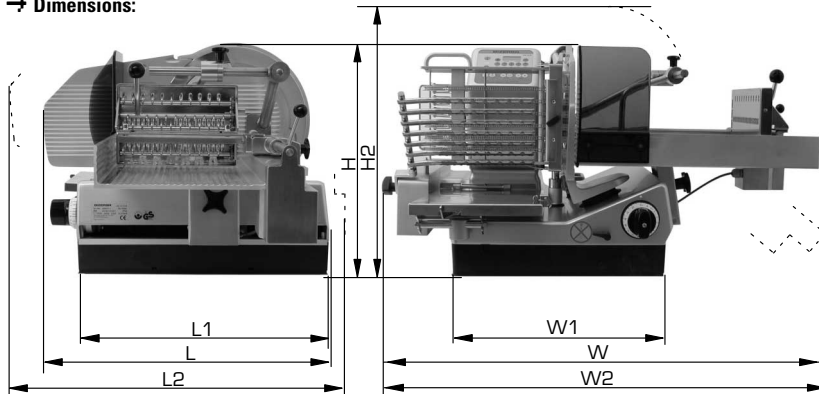

** THE VS 12D-V WITH CARRIAGE FOR 380 MM (15") CLAMPED PRODUCT LENGTH.



BIZERBA

_balanced information